

TableTop Conveyor

PROCore®
by  **NERCON**

Available in 3.25", 4.5", 7.5", and 12"
chain with open top frame design

Committed to Quality Conveyor

Nercon's [TableTop conveyor system](#) offers a versatile design, which makes it a popular conveyor system suited for a wide range of production environments. The flat top plates are stronger than modular belting and transport items through production more efficiently and safely. TableTop conveyors have excellent flexibility for production line layouts, being suitable for curves or changes in elevation, thus streamlining factory operations.



FEATURES

- Low friction values
- High resistance to wear
- Low noise level
- Wide chain applications
- Stronger chain configurations
- Easily integrate with existing systems

INDUSTRY SEGMENTS

- Snack Food & Bakery
- Packaged Foods
- Beverage
- Confectionery & Candy
- Dairy Food
- Produce
- Health & Beauty

APPLICATION TYPES

- Bottles
- Cans
- Cartons
- Cases
- Glass
- Pouches
- Pucks
- Trays

TableTop Design Options

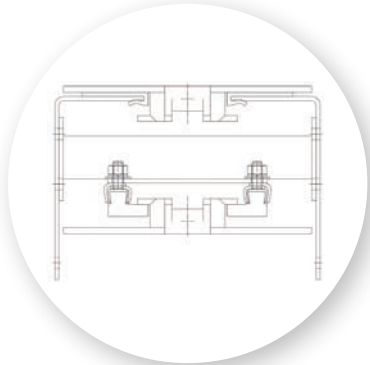

Open Top

The industry standard for industrial-duty TableTop conveyor features inverted "L" side frames to provide rigid support for chain and brackets.

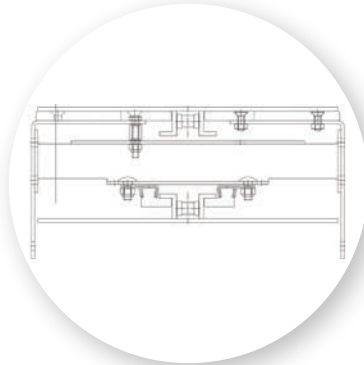

Safety Design

12" wide safe design TableTop conveyor has a frame and wearstrip design that minimizes dangerous pinch-point areas, reducing safety incidents and downtime associated with pinch-point accidents.

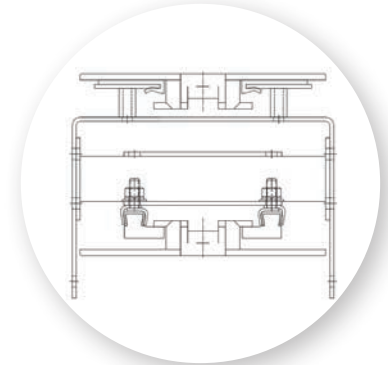

Closed Top

Intended for use on TableTop conveyors where ease of cleaning is required.

TableTop Transfer Designs



Inline Transfer

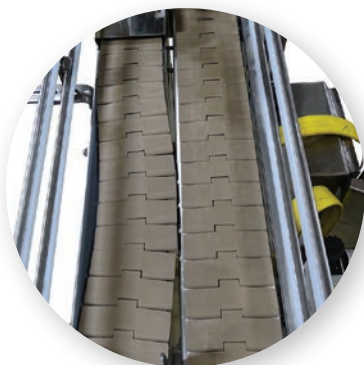

Chain Drift



Parallel Transfer

For more information and videos about Nercon's conveyor systems visit our website: www.nerconconveyors.com



Subscribe to Nercon's Blog
www.nerconconveyors.com

Made in
the U.S.A. 



600 S. Commercial Street | Neenah WI 54956
toll free 844-293-2814 | www.nerconconveyors.com

© 2018 Nercon, Inc. All rights reserved. 11/18 000 SELL-TT